

**Pionite® Postforming** Type F39 HPL is designed for manufacturing countertops and other horizontal surfaces where the laminate may be heated and rolled over the substrate edge to eliminate seams.

Type F28 is designed for applications where impact resistance is less critical. Type F28 can also be postformed.

### Product Composition

Postforming high pressure laminate is manufactured in a flat press by combining decorative papers saturated in melamine resin with phenolic-impregnated kraft layers at pressures exceeding NEMA specifications of 1000 psi (6.9 MPa) and temperatures approaching 300 °F (150 °C). The panels are trimmed to size and the backs are sanded to facilitate bonding. The thickness of the laminate is determined by the number of kraft layers used. The laminating process combines the durability of melamine resins with the aesthetics of decorative papers creating a surfacing material that has been the standard for many years.

### Product Description

#### Standard Nominal Sizes

Type	Thickness*	Width*	Length	Colors
F39 (in.) (mm)	0.036 ± 0.005 0.91 ± 0.13	36, 48, 60 914, 1219, 1524	96, 120, 144 2438, 3048, 3658	All solids, patterns & woodgrains
F28 (in.) (mm)	0.028 + 0.001 - 0.004 0.71 + 0.03 - 0.10	36, 48, 60 914, 1219, 1524	96, 120, 144 2438, 3048, 3658	All solids, patterns & woodgrains

Other widths are available upon request.

### Examples of Postformed Bullnose

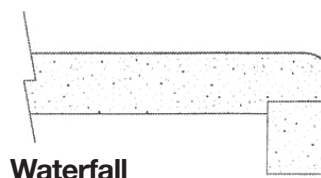
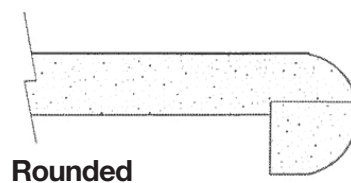
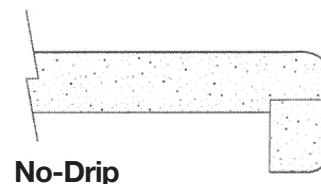
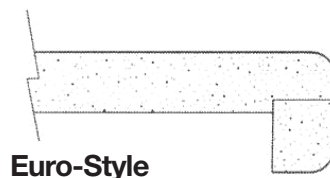

### Finish Options

Please refer to HPL Finishes Chart on the web site to confirm available finishes for this product.

### Typical Uses

Postforming laminate is used in applications where a rolled edge is desirable. The rolled edge eliminates seams and produces a smooth, attractive appearance to the finished assembly. Typical uses include countertops, cabinet doors, drawer fronts and desktops.

### Fabrication Tips

When working with Pionite, these techniques will produce a quality application.

1. Proper conditioning of the laminate, substrate, and backing sheet minimizes possible warping, shrinking, or expansion of assembled panels. Ideally, all components should be conditioned at 70 °F to 75 °F (21 °C to 25 °C) and 45 to 50 percent relative humidity for 48 hours prior to assembly.
2. Always bond laminate to a suitable substrate such as medium to high density fiberboard, particleboard, or metals. It should not be glued directly to plaster walls, gypsum wallboard, or concrete.
3. Recommended adhesives include solvent or water-based contact cement, white glue (PVA), epoxy, and hot melt glue. Consult your adhesive supplier for specific application requirements.

## Cross Section of a Postformed Countertop

Backsplash

Inside Radius (Cove)

Sink Cutout

Scribe Rail

Backsplash Substrate

Cove Stick

Deck Substrate

Drip Edge

Outside Radius (Bullnose)

Build Down

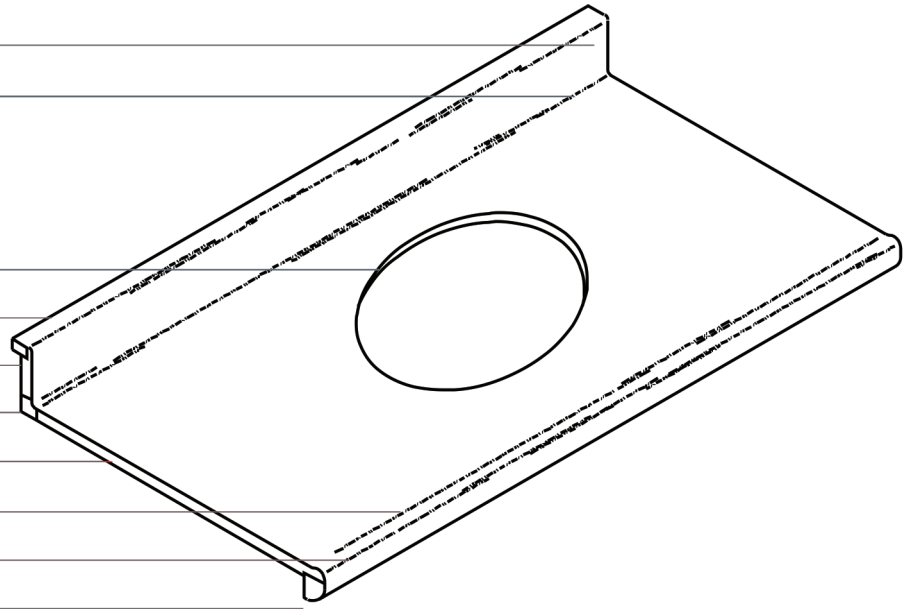

4. The use of a backing sheet is recommended to minimize warpage. The thickness of the backing sheet should be relatively equal to the thickness of the decorative laminate on the face of the assembly.
5. All saw blades and router bits used for cutting should be carbide tipped. Feed rate should be slow and tool speed should be high. To minimize the development of surface scratches caused by router bits, lubricating the laminate edge with a wax stick is recommended prior to tooling.
6. All edges of laminate should be filed smooth with file direction towards substrate to help prevent stress cracks and to minimize chipping.
7. Inside corners of cutouts for electrical outlets, sinks, etc., should have a minimum radius of 1/8" (3 mm) and be filed smooth. This reduces the likelihood of stress cracks.
8. When fasteners are required, it is advisable to first drill an oversized hole through the laminate. This reduces the likelihood of stress cracks.
9. All laminate is intended for interior use only, and should not be exposed to extreme humidity, continuous sunlight, or temperatures above 275 °F (135 °C) for extended periods of time.

## Postforming Tips

When working with Pionite® HPL, these techniques will produce a quality application.

1. Proper conditioning of the laminate, substrate, and backing sheet minimizes possible warping, shrinking, or expansion of assembled panels. Ideally, all components should be conditioned at 70 °F to 75 °F (21 °C to 25 °C) and 45 to 50 percent relative humidity for 48 hours prior to assembly.
2. The radiused edge of the substrate must be smooth, rounded, and free of irregularities and loose particles.
3. Lead-in cracks may be minimized by ensuring a smooth cut on the edge of the laminate.
4. Always bond laminate to a suitable substrate such as medium to high density fiberboard, particleboard, or metals. It should not be glued directly to plaster walls, gypsum wallboard, or concrete.
5. Recommended adhesives include postformable solvent or water-based contact cement, white glue (PVA), and epoxy. Consult your adhesive supplier for specific application requirements.
6. The use of a backing sheet is recommended to minimize warpage. The thickness of the backing sheet should be relatively equal to the thickness of the decorative laminate on the face of the assembly.
7. The decorative surface to be formed should be heated to a temperature of 325 °F to 375 °F (165 °C to 190 °C).
8. The desired heat-up rate to 325 °F (165 °C) should be one second for every .001" of thickness (i.e., 28 seconds for F28, 39 seconds for F39).

9. Forming should be accomplished within 5 seconds of achieving proper surface temperature.
10. Heat-up rates of laminate are affected by thickness, color, and finish. Temperatures should be verified by temperature-indicating wax (Tempilaq®).

## Technical Information

### Physical Properties

TEST		NEMA LD 3-2005 Test Method	TYPICAL PIONITE® VALUES F39	NEMA STD. HGP	TYPICAL PIONITE® VALUES F28	NEMA STD. VGP
Thickness	(in.) (mm)		0.036 ± 0.005 0.91 ± 0.13		0.028 + 0.001 - 0.004 0.71 + 0.03 - 0.10	
Appearance		3.1	Complies		Complies	
Light Resistance		3.3	Slight effect	Slight effect	Slight effect	Slight effect
Cleanability	Stain 1-10 Stain 11-15	3.4	13 No effect No effect	20 (max.) No effect Moderate effect	8 No effect No effect	20 (max.) No effect Moderate effect
Boiling Water Resistance		3.5	No effect	Slight effect	No effect	Slight effect
High Temperature Resistance		3.6	No effect	Slight effect	No effect	Slight effect
Ball Impact Resistance	(in.) (mm)	3.8	35 889	30 (min.) 750 (min.)	30 762	20 (min.) 500 (min.)
Radiant Heat Resistance	(sec)	3.10	165	100 (min.)	155	80 (min.)
Dimensional Change		3.11				
Machine Direction	(%)		0.40	1.10 (max.)	0.40	1.10 (max.)
Cross Direction	(%)		0.80	1.40 (max.)	0.80	1.40 (max.)
Room Temperature Dimensional Stability		3.12				
Machine Direction	(%)		0.16	1.0	0.18	1.0
Cross Direction	(%)		0.48	1.3	0.37	1.3
Wear Resistance	(cycles)	3.13	700	400 (min.)	700	400 (min.)
Formability	(in.) (mm)	3.14	9/16 14	5/8 (min.) 16 (min.)	7/16 11	1/2 (min.) 13 (min.)
Blister Resistance	(sec)	3.15	65	55 (min.)	50	40 (min.)

## Fire Test Data

High pressure decorative laminate is frequently used in installations governed by local fire codes. Burning characteristics of laminate are greatly influenced by the adhesive and substrate used. Listed are typical flame spread index and smoke developed values for Pionite® postforming laminate. When specifying Class I or A rated laminate, refer to Pionite® Fire Rated Technical Bulletin.

### ASTM E-84/UL723

#### “Standard Test Method for Surface Burning Characteristics of Building Materials”

Type	Configuration	Flame Spread Index	Smoke Developed Values
F39	Unbonded	40	65
F28		35	35
F39	Bonded to Inorganic	55	105
F28	Cement Board	35	40
F39	Bonded to 5/8"	235	140
F28	Particleboard	160	160
F39	Bonded* to 5/8" Fire	110	130
F28	Rated Particleboard	80	75

### CAN/ULC-S102M

#### Laminated Plastic Surface Burning Characteristics

Type	Configuration	Flame Spread Index	Smoke Developed Values
F39	Bonded* to Inorganic	45	20
F28	Cement Board	35	10

\*Bonded with N® Sodium Silicate Sealer and Wonderbond WB-104A with M-172L. All work should be designed, assembled, and installed in compliance with pertinent local fire codes.

## Codes and Certifications

1. U.S. Federal Motor Vehicle Safety Standard #302 “Flammability of Interior Materials.” Pionite® Type F39 and F28 comply.
2. The City of New York, Dept. of Buildings, Materials and Equipment Acceptance Division approval codes are as follows:  
F39 - MEA 206-93-M  
F28 - MEA 208-93-M
3. NSF International Standard 35, “Laminated Plastics for Surfacing Food Service Equipment.” Pionite® Type F39 and F28 comply.
4. American National Standards Institute/National Electrical Manufacturers Association (ANSI/NEMA), LD3-2005, “High- Pressure Decorative Laminate.” Pionite® Type F39 and F28 comply.

5. U.S. Federal Specification L-P-508H, “Plastic Sheet, Laminated, Decorative and Nondecorative.” Pionite® Type F39 and F28 comply.
6. International Organization for Standardization, ISO-4586, “Decorative High Pressure Laminates (HPL).” Pionite® Type F39 and F28 comply.

## Care and Maintenance

Pionite® decorative laminate provides a durable surface that is easy to maintain using ordinary care. To maintain the laminate’s lasting beauty, cleaning with a solution of warm water and liquid dishwashing detergent is all that should be required in most cases.

Stains may be removed with most non-abrasive household cleaners such as FORMULA 409®, GLASS PLUS® or WINDEX® with AMMONIA D®. Light scrubbing with a soft bristled brush may be necessary to remove stains from the depth of the structure on some textured surfaces.

If the stain persists, use a paste of baking soda and water and apply with a soft bristled brush. Light scrubbing for 10-20 strokes should remove most stains. Although baking soda is a low abrasive, excessive scrubbing or exerting too much force may damage the decorative surface, especially if it has a gloss finish.

Stubborn stains that resist any of the above cleaning methods may require the use of undiluted household bleach. Apply the bleach to the stain and let stand no longer than 1-1/2 minutes. Rinse thoroughly with warm water and wipe dry. This step may be repeated if the stain appears to be going away and the color of the laminate has not been affected. WARNING: Prolonged exposure of the laminate surface to bleach will cause discoloration.

Many commercially available products contain substances that may damage or discolor a laminate surface. ABRASIVE CLEANERS SHOULD NOT BE USED. Particular care should be used with any products labeled CAUTION or WARNING. Any questions or concerns should be referred to the product’s manufacturer or call 1-877-726-6526. Do not allow harsh materials to remain in contact with the laminate surface. Examples of these are as follows:

N® Sodium Silicate Solution is a product of PQ Corporation P. O. Box 840, Valley Forge, PA USA Wonderbond® WB-104A with M-172L is a product of Momentive Specialty Chemicals, Inc. 180 East Broad Street Columbus, OH 43215

Formula 409 is a registered trademark for The Clorox Company of Oakland, CA 94612; Glass Plus is a registered trademark for The Dow Chemical Company of Indianapolis, IN 46268-0511; Windex is a registered trademark for S.C. Johnson & Sons INC. of Racine, WI 53403-5011.

- Toilet bowl cleaners
- Chlorine bleach
- Hydrogen Peroxide
- Coffee pot cleaners
- Oven cleaners
- Hard water stain removers
- Drain cleaners
- Fruit and berry juice
- Metal cleaners and polishes
- Tub and tile cleaners

### Limited Warranty

Subject to the limitations set forth below, Panolam Industries International Inc. (Panolam) expressly warrants that our products are reasonably free of defects in material and workmanship, and when properly handled and fabricated will conform, within accepted tolerances, to applicable manufacturing specifications as set forth in our technical brochure. This warranty shall extend to the original buyer for a period of twelve (12) months from the date of shipment of this product by Panolam, and shall not be assignable by the original buyer. This warranty does not cover damage resulting from accident, misuse, alteration, abuse or lack of reasonable care.

Due to the variety of uses and applications to which this product may be put, and because the manufacturer has no control over the end products fabricated, the warranty set forth above is exclusive and in lieu of all warranties, expressed or implied, in fact or by operation of law or otherwise, or arising by course of dealing or performance, custom or usage in the trade, including, without limitation, the implied warranties of fitness for a particular purpose and merchantability, and Panolam shall have no obligation or liability to any person or entity in connection with or arising from the furnishing, sale, installation or repair, use or subsequent sale of any product supplied by it.

Our maximum liability arising out of the sale of the products or their use, whether based upon warranty, contract, tort or otherwise, shall not exceed the actual payments received by us in connection therewith. In no event shall we be liable for special, incidental or consequential damages, including, but not limited to, arising hereunder or from the loss of profits, or loss of use damages, sales of the products.

### Headquarters

Panolam Industries International, Inc.  
 2 Corporate Drive, Suite 946  
 Shelton, CT 06484  
**1-877-726-6526**  
[www.panolam.com](http://www.panolam.com)



© 2024 Panolam Industries International, Inc.

5/2024